

Wireless Network Based Automatic Irrigation System

A. Anusha¹, D. Gouthami²

M.Tech, PG Student¹

Assistant Professor²

Abstract: Agriculture is the source of livelihood of majority Indians and it also has a great impact on economy of the country. In dry areas or in places where there is inadequate rainfall or when a farmer is not aware of how to use water when there is too much of water storage or when there is no water storage irrigation becomes tedious. Wireless sensor networks and their application for precision agriculture is an automated irrigation system used to enhance the use of water for agricultural crops. The system consists of a wireless network that is the soil moisture sensor and temperature sensor placed under the soil where plants roots are reached which is a distributed network. The system has a water level sensor which will indicate the presence of water level in tank. A gateway unit manages the information related to sensors which triggers the actuators, and data is transmitted using GSM module.

Keywords: Automation, Internet, Irrigation system, Wireless Sensor Network (WSN).

I. INTRODUCTION

Indian economy is basically depends on agriculture. Agriculture uses most of available fresh water resources and this use of fresh water resources will continue to be increases Because of population growth and increased food demand. Increased labour costs, stricter Environmental regulations and increased competition for water resources from urban areas Provide strong motivation for efficient Irrigation system. The automated irrigation system is feasible and cost effective for optimizing water resources for agricultural production.

Using the automated irrigation system we can prove that the use of water can be reduced for different agricultural production. The irrigation system provide only required amount of water to crop. This automated irrigation system allows it to be scaled up for larger greenhouses or open fields. An automated irrigation system was developed to optimize water use for agricultural crops. The system has a distributed wireless network of soil moisture and temperature sensors placed in the root zone of the plants and water level sensor is placed in tank for checking the water level in tank. In addition, a gateway unit handles sensor information, triggers actuators, and transmits data to a web application. An algorithm was developed with threshold values of temperature, soil moisture and water level that was programmed into a micro-controller based gateway to control water quantity.

II. AN OVERVIEW ON SOME PREVIOUS IRRIGATION SYSTEM

In some of the irrigation system irrigation scheduling is achieved by monitoring soil, water status with tension meters under drip irrigation by the automation controller

system in sandy soil. It is very important for the farmer to maintain the content in the field. In this the design of a Micro-controller based drip irrigation mechanism is proposed, which is a real time feedback control system for monitoring and controlling all the activities of drip irrigation system more efficiently. Irrigation system controls valves by using automated controller allows the farmer to apply the right amount of water at the right time, regardless of the availability of the labour to turn valves[1]. Some irrigation systems are used to implement efficient irrigation scheme for the field having different crops. The system can be further enhanced by using fuzzy logic controller. The fuzzy logic scheme is used to increase the accuracy of the measured value and assists in decision making [2]. The green house based modern agriculture industries are the recent requirement in every part of agriculture in India. In this technology, the humidity and temperature of plants are precisely controlled.

Due to the variable atmospheric conditions sometimes may vary from place to place in large farmhouse, which makes very difficult to maintain the uniformity at all the places in the farmhouse manually. For this GSM is used to report the detailed about irrigation. The report from the GSM is send through the android mobile [3]. The software and hardware combine together provide a very advanced control over the currently implemented manual system. The implementation involves use of internet for remote monitoring as well as control of Drip Irrigation system. This system uses sensors like humidity, soil moisture. These sensors send values to micro-controller. Micro-controller sends values to PC using serial communication. According to real time sensors values continuous graph is display on PC and Android Based mobile using Internet and Android application. Here threshold value is keep, if

sensor values cross the threshold value then Drip Irrigation components can be control automatically by micro-controller. User can also control Drip Irrigation from anywhere via Android mobile [4]. In the Micro-controller based drip irrigation mechanism, this is a real time feedback control system for monitoring and controlling all the activities of drip irrigation system more efficiently. Irrigation system controls valves by using automated controller to turn ON OFF. This allows the farmer to apply the right amount of water at the right time, regardless of the availability of the labour to turn valves or motor ON OFF. This reduces runoff over watering saturated soils avoid irrigating at the wrong time of the day. It improves crop performances and help in time saving in all the aspects [5]. The management of this kind of farms requires data acquisition in each greenhouse and their transfer to a control unit which is usually located in a control room, separated from the production area.

At present, the data transfer between the greenhouses and the control system is mainly provided by a suitable wired communication system, such as a field bus. In such contexts, even though the replacement of the wired system with a fully wireless one can appear very attractive, a fully wireless system can introduce some disadvantages. A solution based on a hybrid wired/wireless network, where Controller Area Network and ZigBee protocols are used. In particular, in order to integrate at the Data Link Layer the wireless section with the wired one, a suitable multi-protocol bridge has been implemented. Moreover, at the Application Layer, porting of Smart Distributed System services on ZigBee, called ZSDS, allows one to access the network resources independently from the network segment [6]. The some system highlights the development of temperature and soil moisture sensor that can be placed on suitable locations on field for monitoring of temperature and moisture of soil, the two parameters to which the crops are susceptible. The sensing system is based on a feedback control mechanism with a centralized control unit which regulates the flow of water on to the field in the real time based on the instantaneous temperature and moisture values [7]. Some system presents Artificial Neural Network (ANN) based intelligent control system for effective irrigation scheduling. The proposed Artificial Neural Network (ANN) based controller was prototyped using MATLAB. The input parameters like air temperature, soil moisture, radiations and humidity are modeled. Then using appropriate method, ecological conditions, evapotranspiration and type of crop, the amount of water needed for irrigation was estimated and then associated results are simulated.

III. BLOCK DIAGRAM

MAX-232 version of serial I/O standard is most widely used in PCs, GSM/GPS and several devices. In MAX232, high and low bits are represented by fallowing voltage ranges. The MAX232 has 2 sets of line drivers for transferring and receiving data's shown in fig. The line

drivers used for TxD are called T1 and T2, while the line drivers RxD are designated as R1 and R2. The MAX232 is an integrated circuit that converts signals from an RS-232 serial port to signals suitable for use in TTL compatible digital logic circuits. The MAX232 is a dual driver/receiver and typically converts the RX, TX, CTS and RTS signals.

The drivers provide RS-232 voltage level outputs (approx. ± 7.5 V) from a single + 5 V supply via on-chip charge pumps and external capacitors. This makes it useful for implementing RS-232 in devices that otherwise do not need any voltages outside the 0 V to + 5 V range, as power supply design does not need to be made more complicated just for driving the RS-232 in this case. The receivers reduce RS-232 inputs (which may be as high as ± 25 V), to standard 5 V TTL levels. These receivers have a typical threshold of 1.3 V, and a typical hysteresis of 0.5 V. The later MAX232A is backwards compatible with the original MAX232 but may operate at higher baud rates and can use smaller external capacitors – 0.1 μ F in place of the 1.0 μ F capacitors used with the original device.

A GSM modem is a specialized type of modem which accepts a SIM card, and operates over a subscription to a mobile operator, just like a mobile phone. From the mobile operator perspective, a GSM modem looks just like a mobile phone. Designed for global market, SIM 300 is a Tri-band GSM/GPRS engine that work on frequency EGSM (Extended GSM) 900 MHZ, DCS(Digital cellular service) 1800 MHZ and PCS (Personal Communication Services) 1900 MHZ . SIM 300 provides GPRS multi-slot class 10 capability and support the GPRS (General Packet Radio Service) coding schemes CS-1, CS-2, CS-3 and CS-4. with a tiny configuration of 40mm x 33mm x 2.85mm, SIM 300 can fit almost all the space requirement in your application, such as smart phone, PDA, phone and other mobile device. The physical interface to the mobile application is made through a 60 pins board-to-board connector, which provides all hardware interface between the module and customer's boards expect the RF antenna interface.

AT commands are instructions used to control a modem. AT is the abbreviation of Attention. Every command line starts with 'AT' or 'at'. That is why modem commands are called AT commands. Many commands that are used to control wired dial up modems, such as ATD(Dial), ATA(answer), ATH(hook control) and ATO(return to online data state), are also supported by GSM/GPRS mobile phones. Besides this common AT commands set GSM/GPRS mobile phones support an AT command set that is specific to the GSM technology, which includes SMS related commands, like AT+CGMS (send message), AT+CMSS (send message from the storage), AT+CMGL (list messages) and AT+CMGR (read messages). Note that the starting "AT" prefix that informs the modem about the start of a command line. It is not the part of the AT command name. For example D is the actual AT command name in ATD and +CMGS is the actual AT command name in AT+CMGS, however some books and websites use them interchangeably as the name of an AT

command. A Liquid Crystal Display (LCD) is a thin, flat display device made up of

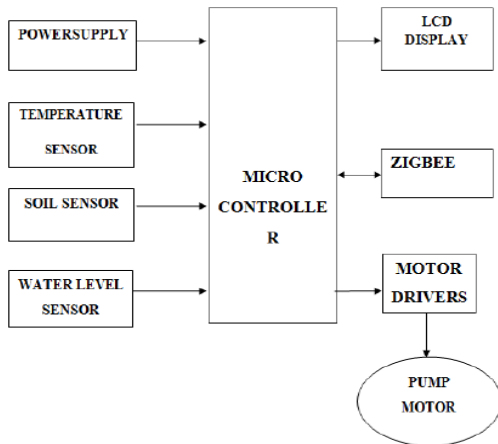

Fig 1 Wireless Sensor Unit

monochrome pixels arrayed in front of a light source or reflector. It is preferred by engineers because it uses very small amount of electric power. Liquid crystal display (LCD) offers several advantages over traditional cathode ray tube that makes them ideal for several applications. Of course LCD's are flat and they use only a fraction of power required by cathode ray tubes. They are easier to read and more pleasant to work with for long periods of time. There are several tradeoffs as well, such as limited view angle, brightness and contrast, not to maintain high manufacturing cost. 16x2 LCD is used in this project to display data to user. There are two rows and sixteen columns. It is possible to display 16 characters on each of the 2 rows. It has registers, command and data register.

Float Sensor is an electrical ON/OFF Switch, which operates automatically when liquid level goes up or down with respect to specified level. The Signal thus available from the Float Sensor can be utilized for control of a Motor Pump or an allied electrical element like Solenoid, Lamps, and Relays etc. Float Sensors contain hermetical sealed Reed Switch in the stem and a permanent Magnet in the Float. As the Float rises or falls with the level of liquid the Reed Switch is activated by Magnet in the Float. You can measure temperature more accurately than a using a thermistor. The sensor circuitry is sealed and not subject to oxidation, etc. The LM35 generates a higher output voltage than thermocouples and may not require that the output voltage be amplified. This is a water pump and valve where both are in a single component. A pump is driven using a voltage of 12V.

This is interfaced to the arm controller indirectly using relay. This relay triggers the 12v voltage and interfaces with arm controller. Then the pump is driven and water is supplied using valve present in that component. Relay is an electrically operated switch. It is used for voltage conversion from 12V to 5V. It consists of normal open, normal close and common pins on one side and on another side it has ground, enable and 12V where input is given to arm controller and Normal open and common are shorted

and given to one end of pump. Soil moisture sensors measure the water content in soil. A soil moisture probe is made up of multiple soil moisture sensors. This Soil Moisture Sensor can be used to detect the moisture of soil or judge if there is water around the sensor, let the plants in your garden reach out for human help. Insert this module into the soil and then adjust the on-board potentiometer to adjust the sensitivity. The sensor would outputs logic HIGH/LOW when the moisture is higher/lower than the threshold set by the potentiometer. With help of this sensor, it will be realizable to make the plant remind you: Hey, I am thirsty now, please give me some water.

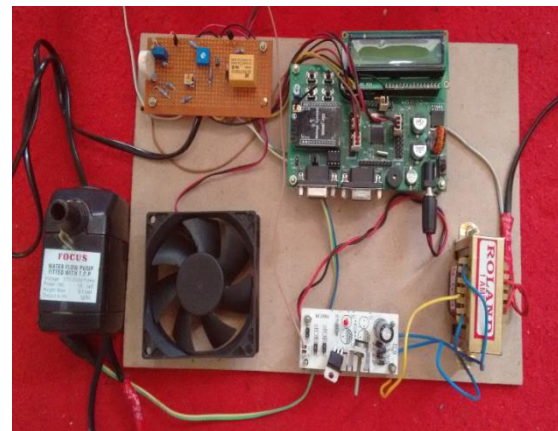

Fig 2 Transmission Section

IV. ADVANTAGES

The system is very economical in terms of hardware component and power consumption. The system helps in saving of water and electricity. It can be implemented in large agricultural areas. With the help of GSM user can control the motor from anywhere by just sending SMS. The system helps in labor problem when there are no labors to work and eliminates man power. System can be switched into manual mode whenever required. It is useful to all climatic conditions and all types of irrigation.

V. APPLICATIONS

Irrigation can be done in fields, gardens, farms etc. It is efficient for varieties of crops. This implementation can be used for patient monitoring. The software application developed for this system can be used for household works such as tank storage. This system can be operated automatically as well as manually.

VI. FUTURE SCOPE

Rain gun sensor can be added so that when it rains there won't be floods and this shield the field and avoids floods. Rain water harvesting can be done and this harvested water can be used to irrigate fields. Hooters can be used so that it gives siren at various occasions such as intrusion

detection, floods etc. Using IR sensors any object passing into fields can be detected and alerted.

VII. CONCLUSION

The automated irrigation system implemented is very feasible and cost effective. The system is very economical in terms of hardware component and power consumption. The system helps in saving of water and electricity. It can be implemented in large agricultural areas. With the help of GSM user can control the motor from anywhere.

REFERENCES

- [1] Veena Divyak ,Ayush Akhouri,A Real time implementation of a GSM based Automated Irrigation Control System using drip Irrigation Methology (Volume 4, Issue 5,May 2013)
- [2] Mansour ,H.A, You sifEl-Melhem ,impact tthe automatic control of closed circuits raingun irrigation system on yellow corn growth and yield(International Journal of Advanced Research (2013), Volume 1, Issue 10, 33-42)
- [3] m. guerbaoui, y. el afou, a. ed-dahhak, a. lachhabpc-based automated drip irrigation system(Vol. 5 No.01 January 2013)
- [4] Purnima, S.R.N Reddy, —Design of Remote Monitoring and Control System with Automatic Irrigation System using GSM Bluetoothl, on IJCA,2012
- [5] Cottet F. (2001): LabVIEW: programmationet applications. Dunod, pp. 415.
- [6] Eddahhak, A.; Lachhab, A.; Ezzine, L.; Bouchikhi, B. (2007): Performance evaluation of a developing greenhouse climate control with a computer system. AMSE Journal Modelling C, 68 (1), pp. 53-64.
- [7] Elattir H. (2005): La conduiteet le pilotage de l'irrigation goutte-àgoutte en maraîchage. Bulletin mensueeld' informationet de liaison duprogramme national de transfert de technologie en agriculture (PNTTA), pp. 124
- [8] Gonzalez, R .A.; Struve, D.K.; Brown L.C. (1992): A computer controlled raingun irrigation system for container plant production Hort Technology, 2(3), pp. 402-407.
- [9] Howell, T.A. (2001): Enhancing water use efficiency in irrigated agriculture. Agron. J, 93, pp. 281-289.
- [10] AbouKheira A. A. (2009). Comparison among different irrigation systems for deficit- irrigated transgenic and non transgenic yellow corn in the Nile Valleyl. Agricultural Engineering International: the CIGR Ejournal. Manuscript LW 08 010. Vol. XI:1 25.
- [11] "Philosophy and Goals". Android Open Source Project.Google. Retrieved2012-04-21.